

UNENCLOSED 90° / ADJACENT EXIT PLATFORM W/ PLATFORM GATE (NO PIT)

VPL-3300B SERIES VERTICAL PLATFORM LIFT

TECHNICAL DATA/SPECIFICATIONS

RATED LOAD:	750 lbs maximum.
INPUT POWER SOURCE:	
-DC BATTERY POWERED UNIT:	110-120 Volt 3 Amp 60 Hz battery charger.
DRIVE:	
-DC BATTERY POWERED UNIT:	1/2 hp motor, 1750 rpm, 24 VDC, continuous duty.
INTERMEDIATE REDUCTION:	Dual 4L style Poly-V belts and pulleys, 3.94:1 pulley reduction.
FINAL DRIVE:	1" dia. ACME screw w/bronze nut and bronze safety back up nut.
MOTOR CONTROLLER:	
-DC BATTERY POWERED UNIT:	24 VDC Relay control.
SPEED:	
-DC BATTERY POWERED UNIT:	10 feet per minute maximum

For complete technical specifications please see
ILS-01100 "VPL-3300B Series Commercial Vertical Platform Lift Technical Specification"

PERFORMANCE STANDARDS

USA FOOD & DRUG ADMINISTRATION: CLASS II, 510(K) Exempt, File No. 890.3930,
Product Code: PCE
ASME A18.1-2011 (Section 2) Safety Standards for Platform Lifts and Stairway Chairlifts
CSA B355-09 Lifts for Persons with Physical Disabilities
CSA B44.1-11/ASME-A17.5-2011 Elevator and Escalator Electrical Equipment

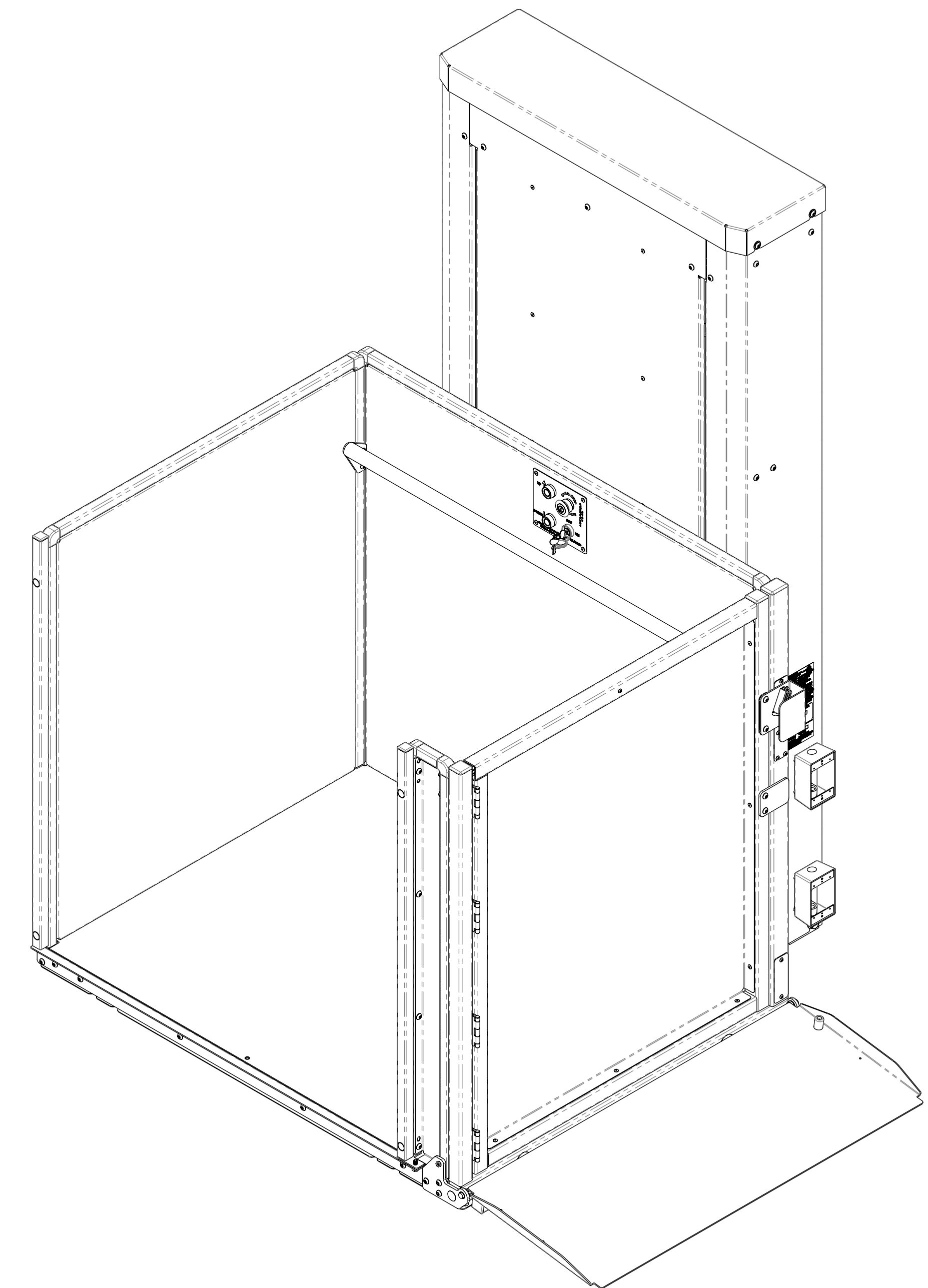

ILS-01104
SHEET 1 OF 3
REV. 1 (5328)(4/8/13)(DPG)

Bruno Independent Living Aids, Inc., 1780 Executive Drive, P.O. Box 84, Oconomowoc, WI 53066
Phone (800) 882-8183 Fax (262) 953-5501

Any reproduction or other use of these materials without written permission of Bruno Independent Living Aids, Inc. is expressly prohibited.
Bruno Independent Living Aids, Inc. reserves the right to modify or make changes to these specifications at any time with out notice.

 **BRUNO**[®]
for your independence
©Bruno Independent Living Aids, Inc.

UNENCLOSED 90° / ADJACENT EXIT PLATFORM W/ PLATFORM GATE (NO PIT)

VPL-3300B SERIES VERTICAL PLATFORM LIFT

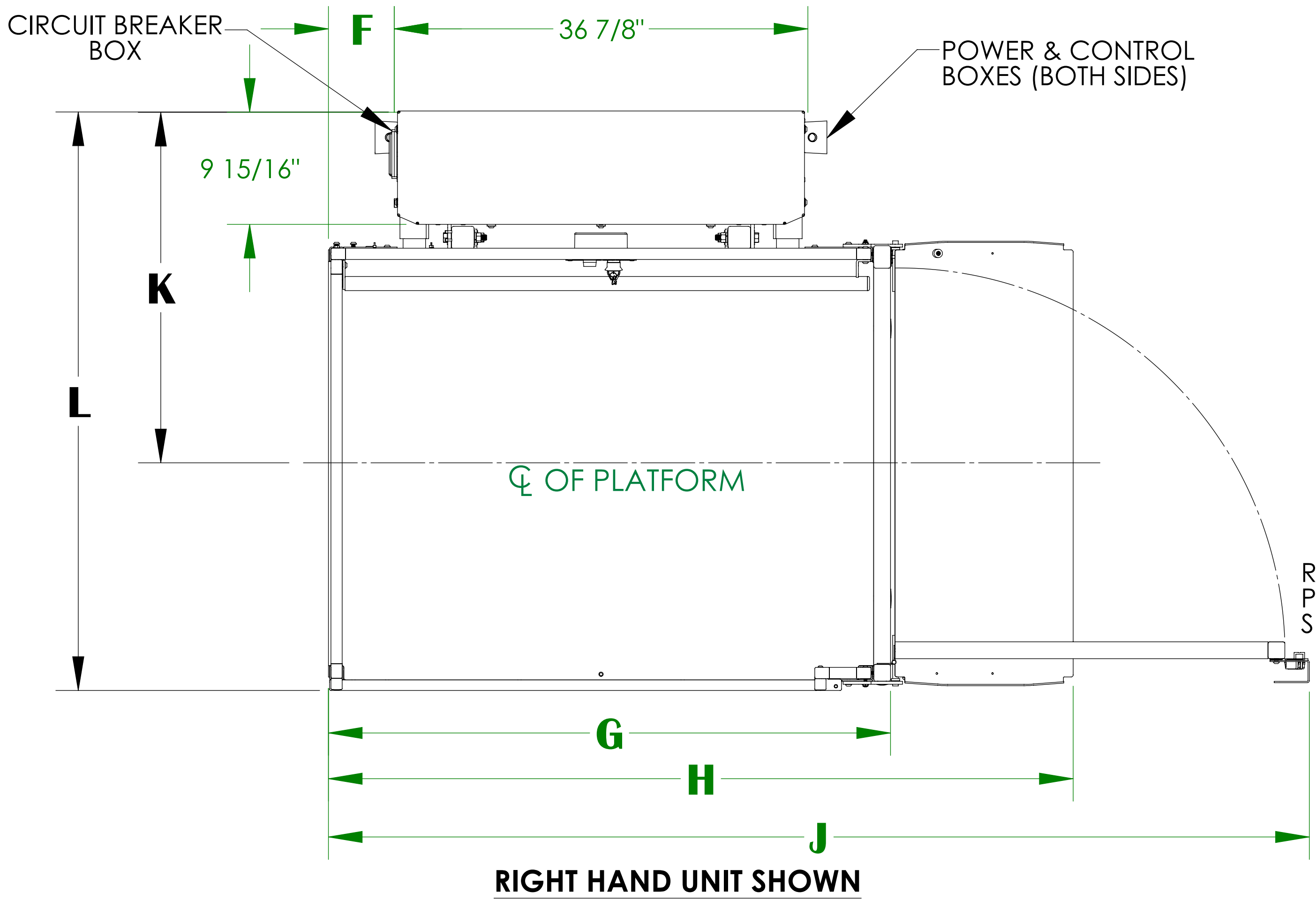

For complete technical specifications please see
ILS-01100 "VPL-3300B Series Commercial Vertical Platform Lift Technical Specification"

	D	E	F	G	H	J	K	L
36" X 48" PLATFORM	36-1/4"	33-1/2"	5-3/4"	49-15/16"	66-1/8"	87-3/16"	31-9/16"	51-11/16"
36" X 54" PLATFORM	36-1/4"	33-1/2"	8-3/4"	55-15/16"	72-1/8"	93-3/16"	31-9/16"	51-11/16"
36" X 60" PLATFORM	36-1/4"	33-1/2"	11-3/4"	61-15/16"	78-1/8"	99-3/16"	31-9/16"	51-11/16"
42" X 60" PLATFORM	42-1/4"	39-1/2"	11-3/4"	61-15/16"	78-1/8"	105-3/16"	34-9/16"	57-11/16"

	A	B	C MIN	C MAX
V P L - 3353 B	75-9/16"	95"	11"	53"
V P L - 3375 B	97-9/16"	117"	32"	60"

RIGHT SWING PLATFORM GATE SHOWN OPEN

RIGHT & LEFT SWING PLATFORM GATES AVAILABLE

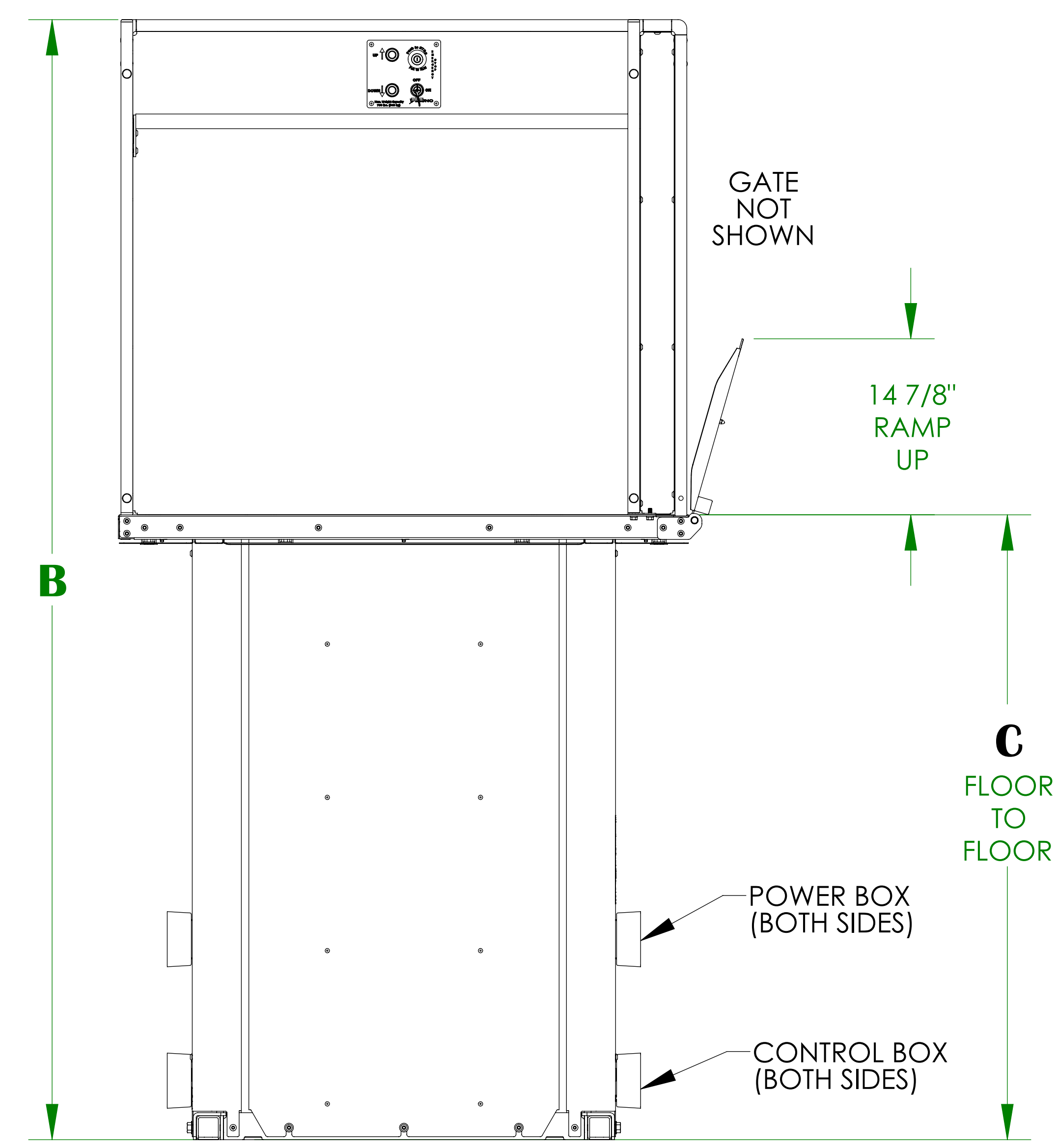
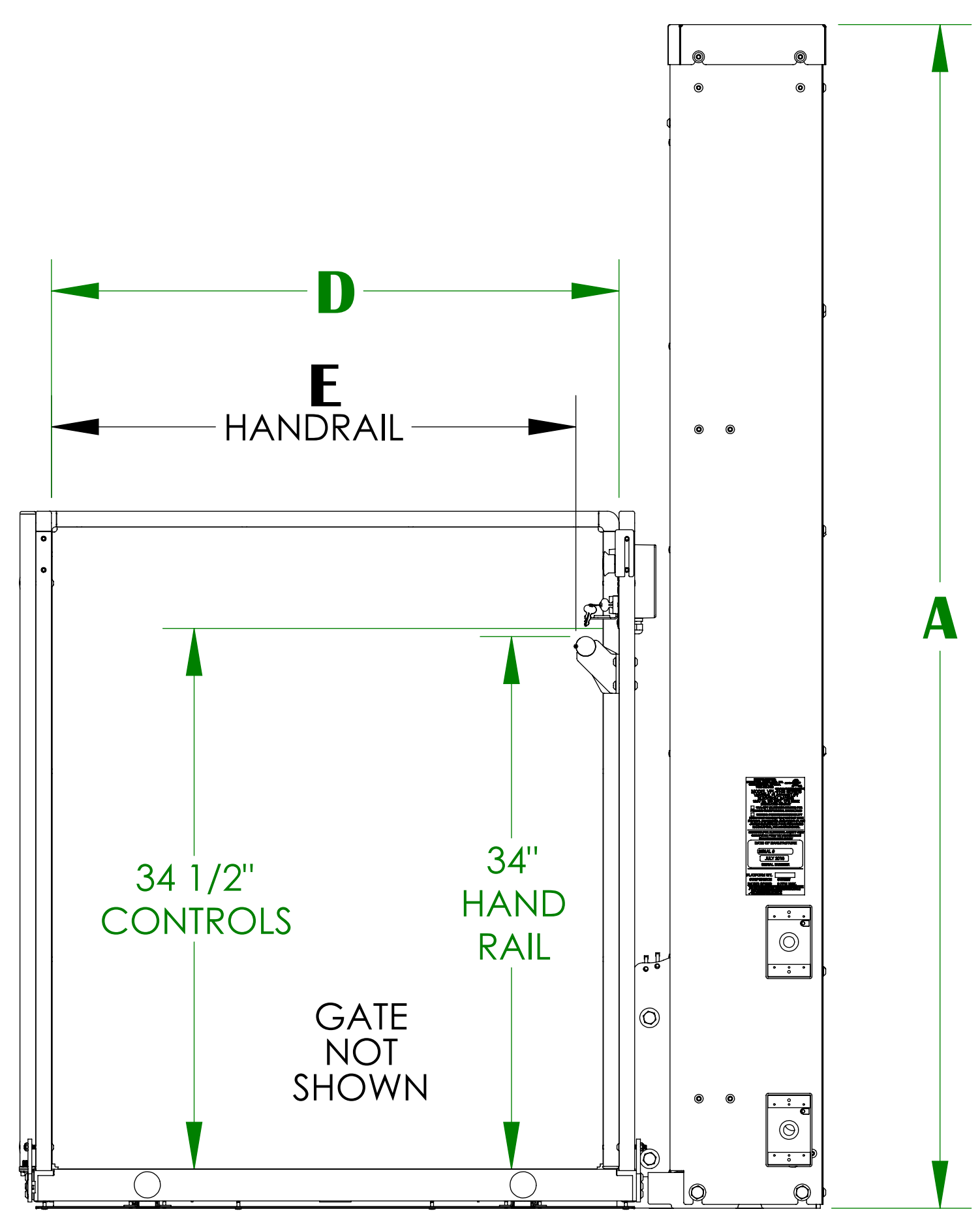
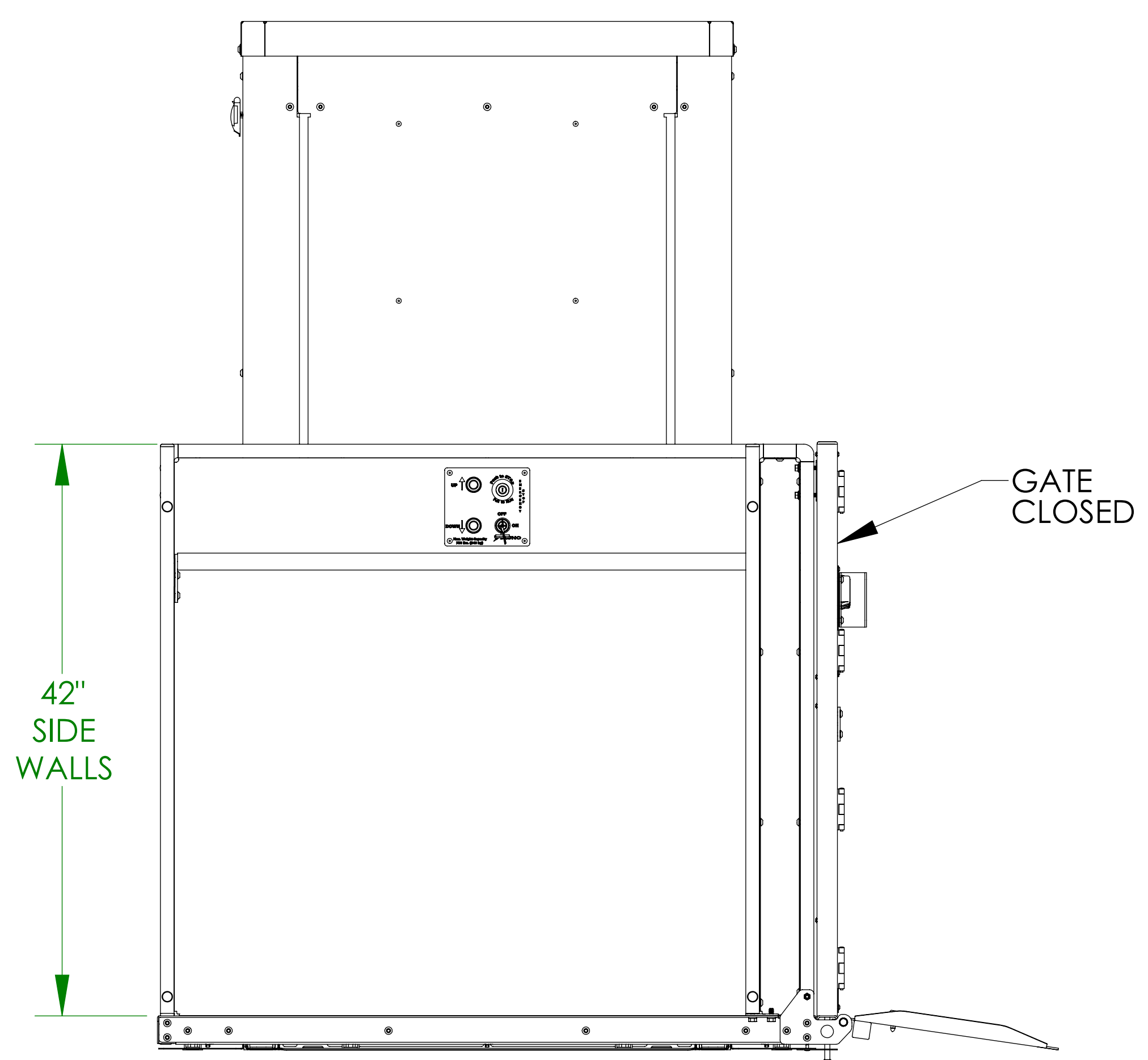

NOTES: 1) ACCESS RAMP & PLATFORM GATE CAN BE MOUNTED ON EITHER SIDE OF THE PLATFORM
 2) SEE ILS-00938 FOR LANDING GATE DETAIL/ALIGNMENT

ILS-01104
SHEET 2 OF 3
REV. 1 (5328)(4/8/13)(DPG)

Bruno Independent Living Aids, Inc., 1780 Executive Drive, P.O. Box 84, Oconomowoc, WI 53066
 Phone (800) 882-8183 Fax (262) 953-5501

Any reproduction or other use of these materials without written permission of Bruno Independent Living Aids, Inc. is expressly prohibited. Bruno Independent Living Aids, Inc. reserves the right to modify or make changes to these specifications at any time without notice.

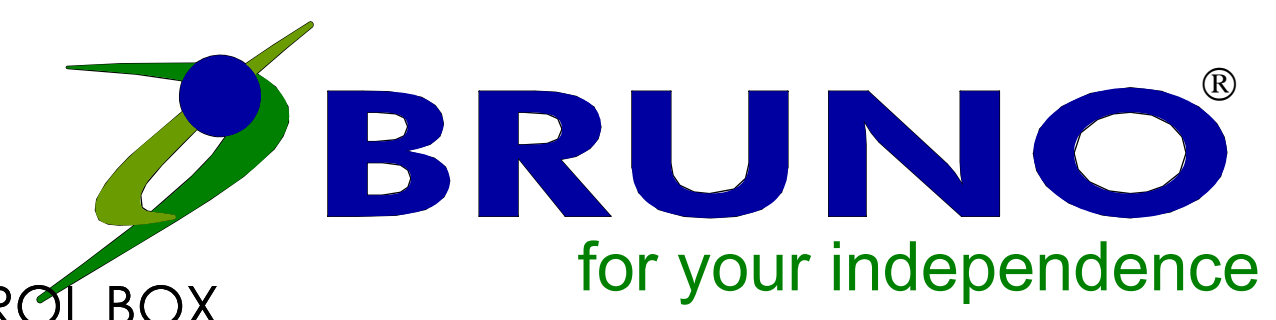

UNENCLOSED 90° /ADJACENT EXIT PLATFORM W/PLATFORM GATE (NO PIT)

VPL-3300B SERIES VERTICAL PLATFORM LIFT ANCHOR POINT LOCATIONS/SLAB DETAIL

TECHNICAL SPECIFICATIONS

FLOOR ATTACHMENT:
 VPL MUST BE FASTENED TO CONCRETE SLAB USING FOUR (4) 1/2" (3/8" BOLT) X MINIMUM 2-1/2" LONG CONCRETE ANCHORS SUITABLE FOR THE ENVIRONMENT. FOLLOW SELECTED CONCRETE ANCHOR MANUFACTURERS GUIDELINES AND APPLICABLE CODES.

FLOOR REQUIREMENTS:
 4" THICK 3500 PSI MINIMUM COMPRESSIVE STRENGTH, REINFORCED CONCRETE SLAB.

For complete technical specifications please see
 ILS-01100 "VPL-3300B Series Commercial Vertical Platform Lift Technical Specification"

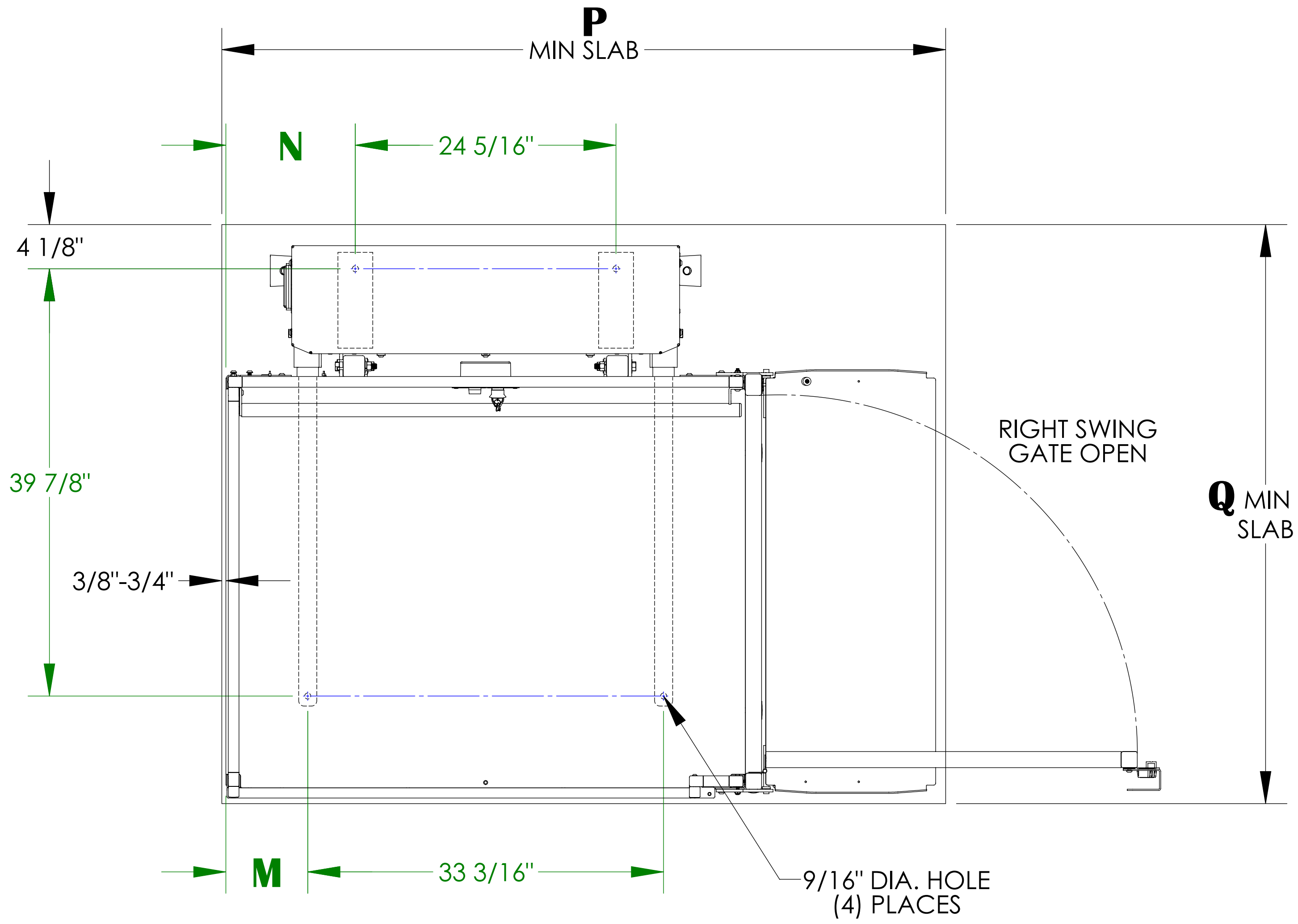

	M	N	P	Q
36" X 48" PLATFORM	7-5/8"	12-1/16"	67-1/2"	54"
36" X 54" PLATFORM	10-5/8"	15-1/16"	73-1/2"	54"
36" X 60" PLATFORM	13-5/8"	18-1/16"	79-1/2"	54"
42" X 60" PLATFORM	13-5/8"	18-1/16"	79-1/2"	60"

UNITS WITH 90° /ADJACENT EXIT PLATFORM WITH PLATFORM GATE